

# Strapping Machine

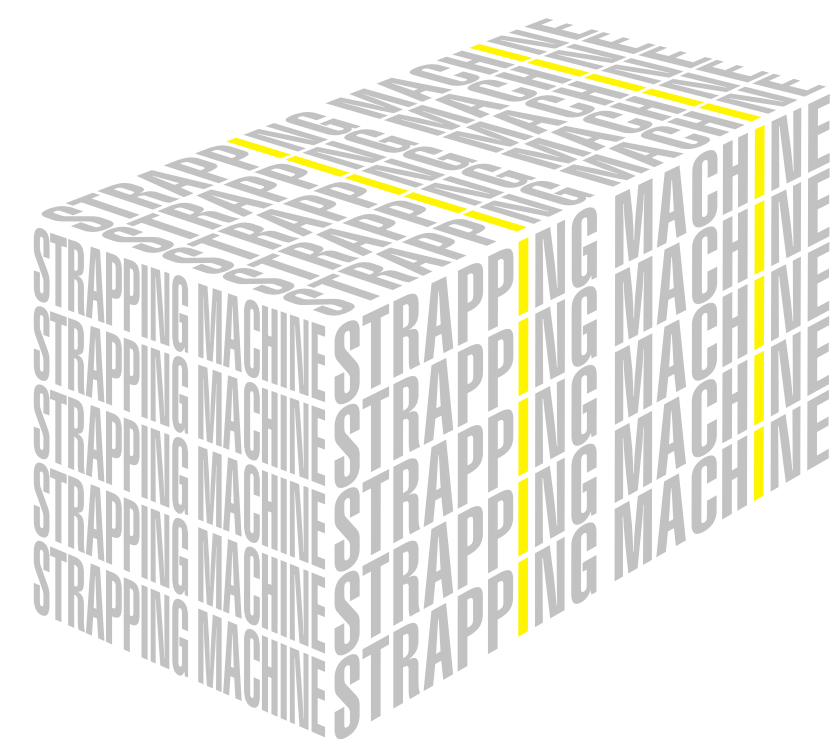

# YS series



## YS-A1 Semi-automactic Strapping Machine

Model	YS-A1
Power supply	380V 50HZ
Packing speed	<=1.5second/cycle
Min.package size	60mm
Max.package size	Unlimited
Max.tension force	35kgs
Applicable belt width	6mm-15mm
Driving motor	Single-phase1/4HP
Size(LxMxH)	895x565x735mm
Net weight	30kgs
Gross weight	70kgs
Specification of paper core	200mm Dia.200mm
G.W/N.W	70kg/30kg

## YS-201 Automatic Strapping Machine

Model	YS-201
Power supply	380V 50HZ 750W 5A
Packing speed	<=2.5second/cycle
Table height	750mm
Frame size	Width 800mm,height depending on actual conditions
Packing type	Parallel 1~several packing strips; in type of order to pack, manual operation, continual packing, ball switch and foot switch.
Applicable straps	Thickness(0.55~1.2)mm, width(9~15)mm
Electric appliances adopted	French "TE", Japanese "OMRON" and "ZIK" available to pack normal goods.



## YS-D Semi-automatic Strapping Machine

Model	YS-D
Power supply	1P 220V 50Hz 1000W
Bailing speed	≤1.5s/circle
Frame size	Width 800mm, height depending on actual conditions.
PP band	Any belting in the market; and 6-15mm yield best adhesive effect.



## YS-305/306 Full-automatic Strapping Machine

Model	YS-305/306
Power supply	380V 50HZ 750W 5A
Packing speed	<=2.5second/cycle
Table height	750mm
Frame size	Width 800mm,height depending on actual conditions
Packing type	Parallel 1~several packing strips; in type of order to pack, manual operation, continual packing, ball switch and foot switch.
Applicable straps	Thickness(0.45~0.55)mm, width(5/6)mm
Electric appliances adopted	French "TE", Japanese "OMRON" and "ZIK" available to pack normal goods.



world advanced packing system

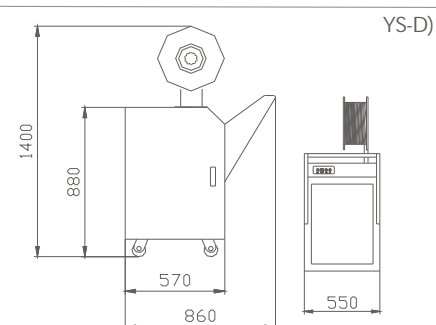

# MH series

## YS-308/309 Full-automatic Strapping Machine

Model	YS-308/309
Power supply	380V 50HZ 750W 5A
Packing speed	<=2.5second/cycle
Table height	750mm
Frame size	Width 800mm,height depending on actual conditions
Packing type	Parallel 1~several packing strips; in type of order to pack, manual operation, continual packing, ball switch and foot switch.
Applicable straps	Thickness(0.45~0.55)mm, width(8/9)mm
Electric appliances adopted	French "TE", Japanese "OMRON" and "ZIK" available to pack normal goods.



## YS-312 Automatic Strapping Machine

Model	YS-312
Power supply	380V 50HZ 750W 5A
Packing speed	<=2.5second/cycle
Table height	750mm
Frame size	Width 800mm,height depending on actual conditions
Packing type	Parallel 1~several packing strips; in type of order to pack, manual operation, continual packing, ball switch and foot switch.
Applicable straps	Thickness(0.55~1.2)mm, width(9~12)mm
Electric appliances adopted	French "TE", Japanese "OMRON" and "ZIK" available to pack normal goods.



## MH-101A Automatic Strapping Machine

• Suitable for packing normal goods.

Model	MH-101A
Power supply	380V 50/60HZ 750W 5A
Packing speed	<=2.5second/cycle
Table height	750mm
Frame size	W(1070)×H(668)mm (Outside) W(800)×H(600)mm (Custom made)
Packing type	Parallel 1~several packing strips; in type of order to pack, manual operation, continual packing, ball switch and foot switch.
Applicable straps	Thickness(0.55~1.2)mm, width(9~15)mm
Electric appliances adopted	LG "PLC" control, French "TE", Japanese "OMRON" and "ZIK" available to pack normal goods.
G.W/N.W	240kg /200kg
Optional	①Aluminum/Iron

world advanced packingsystem

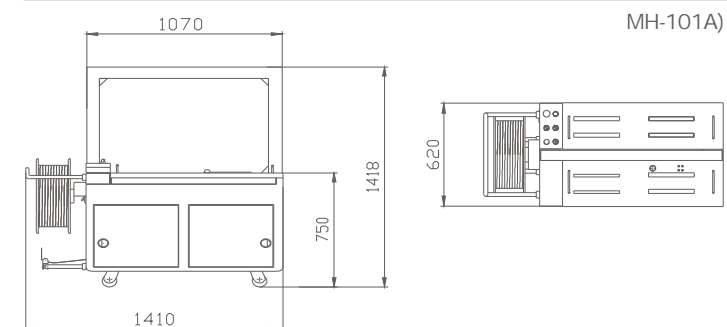



## MH-101B Automatic Strapping Machine

- Suitable for heavy package or package with large volume

Model	MH-101B
Power supply	380V 50/60HZ 750W 5A
Packing speed	<=2.5second/cycle
Table height	450mm (custom-made height is available)
Frame size	(1070)×H(668)mm (Outside) W(800)×H(600)mm (Custom made)
Packing type	Parallel 1-several packing strips; in type of order to pack, manual operation, continual packing, ball switch and foot switch.
Applicable straps	Thickness(0.55-1.2)mm, width(9-15)mm
Electric appliances adopted	LG "PLC" control, French "TE", Japanese "OMRON" and "ZIK" available to pack heavy packages or packages with large volume.
G.W/N.W	330kg/250kg
Optional	①Aluminum/Iron



## MH-102A Full-automatic Unmanned Strapping Machine

- Available to pack heavy packages or packages with large volume.

Model	MH-102A
Power supply	3P 380V 50Hz 1000W 5A (1P 220V 50/60HZ 890W 10A)
Packing speed	<=2.5second/cycle
Table height	450mm(custom-made height is available), available to pack heavy packages or packages with large volume.
Frame size	W1070×H668mm (Outside) W800×H600mm (Custom-made)
Packing type	Parallel 1-several packing strips; in type of photoelectric control, manual operation, etc.
Applicable straps	Thickness(0.55-1.2)mm, width(9-15)mm (can design for actual require)
Electric appliances adopted	LG "PLC" control, French "TE", and photoelectric switch control, with high precision and correctness
G.W/N.W	290kg/240kg
Optional	①Aluminum/Iron



world advanced packing system

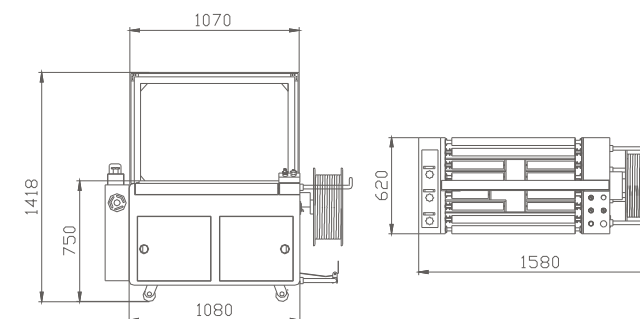
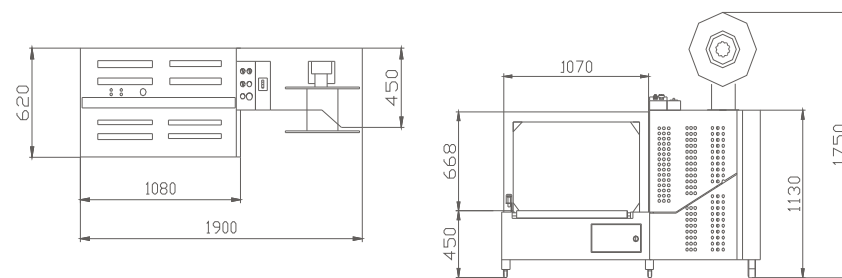

# MH series

7 8

## MH-102B

Full-automatic Unmanned Strapping Machine

- Suitable for packing of heavy package or package with large volume

Model	MH-102B
Power supply	3P 380V 50Hz/60Hz 1200W 5A (1P 220V 50Hz/60Hz 890W 10A)
Packing speed	<=2.5second/cycle
Table height	450mm (custom-made height is available), available to pack heavy packages or packages with large volume.
Frame size	W(1070)×H(668)mm (Outside) W(800)×H(600)mm (Custom made)
Packing type	Parallel 1-several packing strips; in type of photoelectric control, manual operation, etc.
Applicable straps	Thickness(0.55~1.2)mm, width(9~15)mm (can design for actual require)
Electric appliances adopted	OMRON "PLC" control, French "TE", Japanese "OMRON" and "ZIK"
G.W/N.W	370kg/290kg
Optional	①Aluminum/Iron

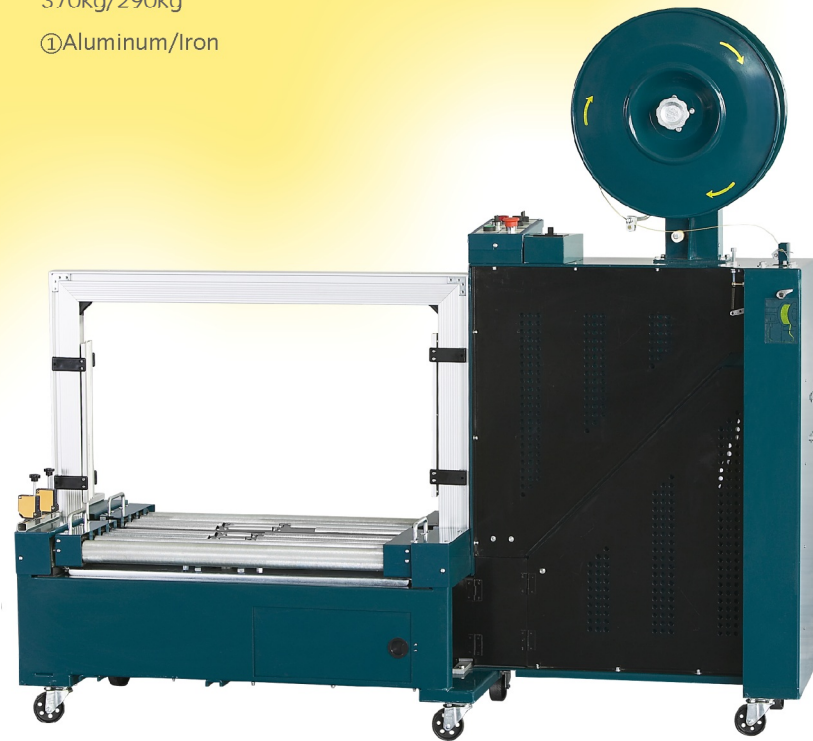

## MH-103A

Automatic Strapping Machine

- Available to pack large-sized packages, especially to those containing liquid and powder-like dropping matters

Model	MH-103A
Power supply	3P 380V 50Hz/60Hz 750W 5A (1P 220V 50Hz/60Hz 490W 7A)
Packing speed	<=2.5second/cycle
Table height	Depending on requirements
Frame size	Width 800mm, height depending on actual conditions
Hot-adhering position	Side face
Packing type	Parallel 1-several strips, in type of order to pack, continually manual packing, manual packing, ball switch and foot switch.
Applicable straps	Thickness(0.55~1.2)mm, width(9~15)mm (can design for actual require)
Electric appliances adopted	LG "PLC" control, French "TE", Japanese "OMRON" and "ZIK"
G.W/N.W	330kg/220kg



world advanced packing system

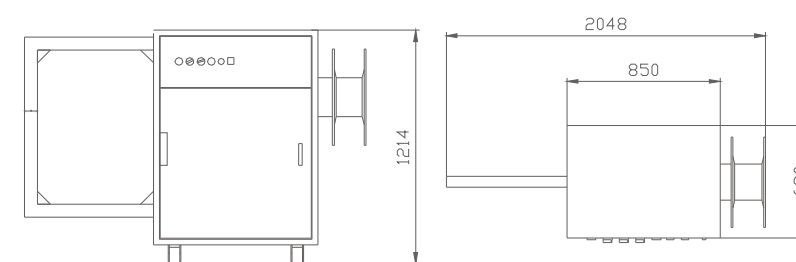
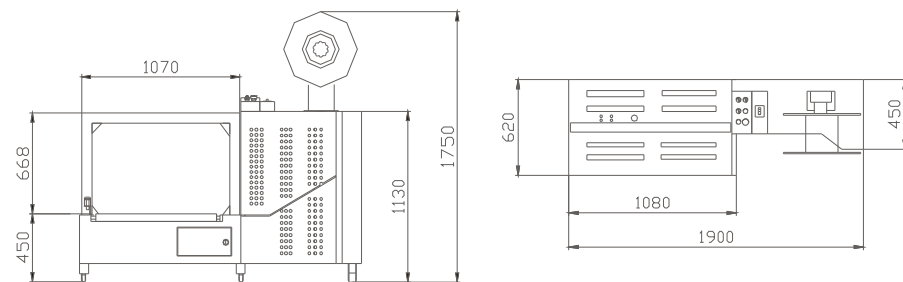

## MH-103B

Full-automatic Unmanned Strapping Machine

- Available to pack large-sized packages, especially to those containing liquid and powder-like dropping matters

Model	MH-103B
Power supply	3P 380V 50Hz/60Hz 750W 5A (1P 220V 50Hz/60Hz 490W 7A)
Packing speed	<=2.5second/cycle
Table height	Depending on requirements
Frame size	Depending on requirements
Hot-adhering position	Side face
Packing type	Parallel 1-several strips, in type of photoelectric control or manual control.
Applicable straps	Thickness(0.55~1.2)mm, width(9~15)mm (can design for actual require)
Electric appliances adopted	"OMRON" and "LG" control, French "TE", photoelectric switch control, precise and correct.
G.W/N.W	330kg/220kg



## MH-104A

Automatic Strapping Machine

- Available to pack goods with extra width.

Model	MH-104A
Power supply	380V 50Hz 750W 5A (220V 50/60HZ 490W 7A)
Packing speed	<=2.5second/cycle
Table height	750mm
Frame size	W1100mm×H600mm (Custom-made)
Packing type	Parallel 1-several strips, in type of order to pack, continually manual packing, manual packing, ball switch and foot switch.
Applicable straps	Thickness(0.55~1.2)mm, width(9~15)mm (can design for actual require)
Electric appliances adopted	LG "PLC" control, French "TE", Japanese "OMRON" and "ZIK"
G.W/N.W	310kg/280kg



world advanced packing system

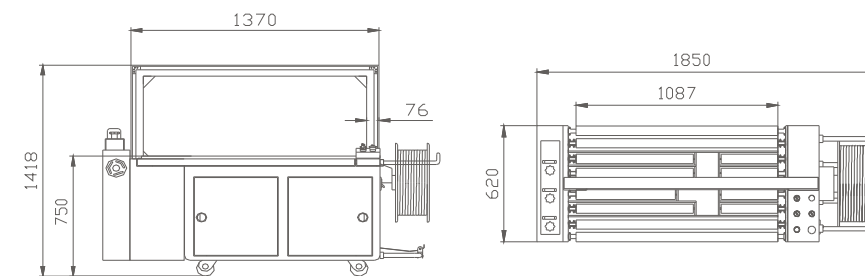
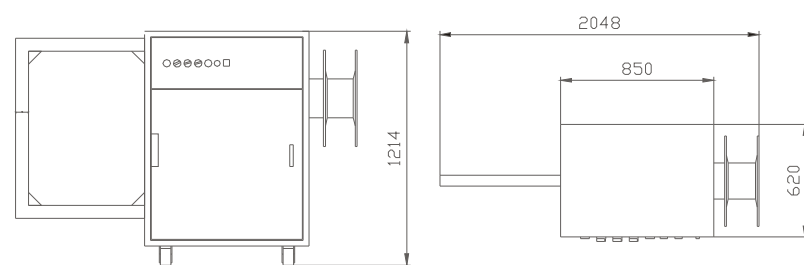



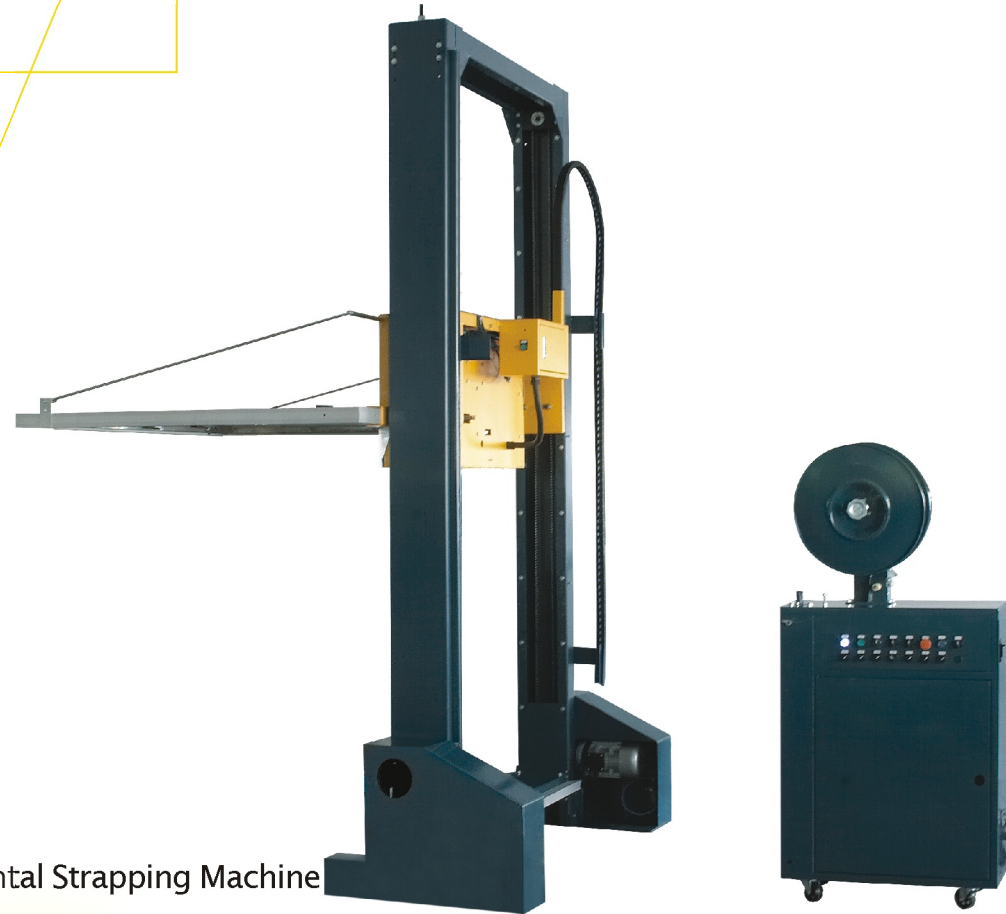

**MH-105A**  
Full-automatic Horizontal Strapping Machine

- Available to pack large-sized goods, used together with Model MH-105B .

Model	MH-105A
Power supply	380V 50HZ 3050W 8A
Packing speed	<=15second/cycle
Table height	Depending on requirements
Frame size	W1500mm×H1500mm (Custom-made)
Packing type	Parallel 1-several strips, in type of order to pack, pedal switch and automatic-controlled twice packing
Applicable straps	Thickness(0.55-1.2)mm, width(12-15)mm (can design for actual require)
Electric appliances adopted	LG "PLC" control, French "TE", Japanese "OMRON" and "MCN"
G.W/N.W	500kg/450kg



**MH-105B**  
Full-automatic Interpenetration Type Strapping Machine

- Especially for pallet

Model	MH-105B
Power supply	3P 380V 50/60HZ 2000W 5A
Packing speed	<=15second/cycle
Table height	Depending on requirements.
Frame size	W(1500)×H(2000)mm (Outside) W(1230)×H(1924)mm (Inside)
Hot-adhering position	Side face
Packing type	Parallel 1-several strips, non-bar type cylinder interpenetration in photoelectric control or manual control.
Applicable straps	Thickness(0.55-1.2)mm, width(12-15)mm (can design for actual require)
Electric appliances adopted	"OMRON" LG"PLC" control, French "TE" and photoelectric switch control, precise and correct.
G.W/N.W	500kg/450kg

world advanced packing system

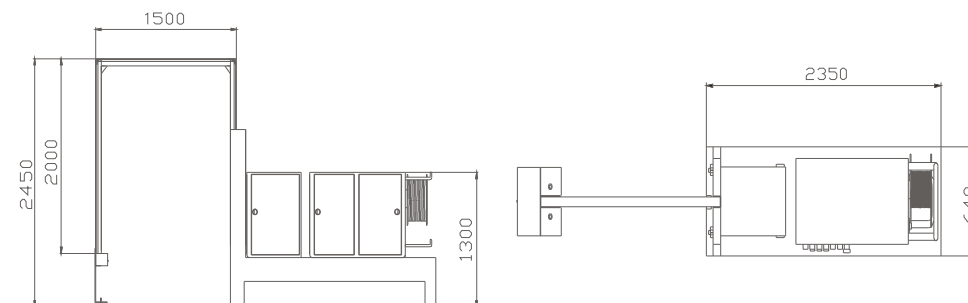
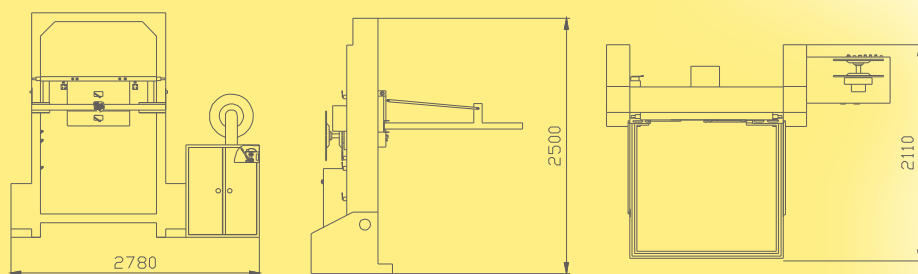

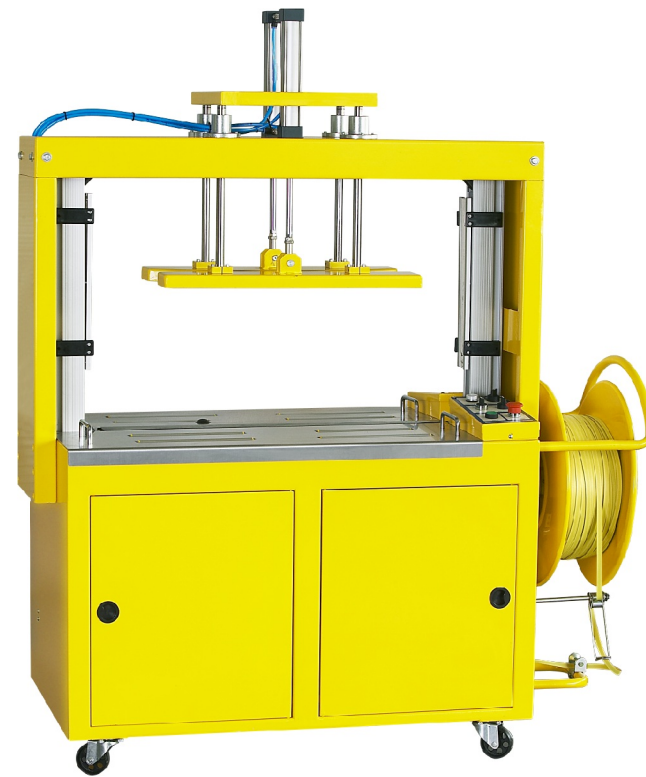

## MH-106A Full-automatic Pressure Strapping Machine

- Especially used to pack bulk goods which need compression before packing, the air pressure is designed to customer's requirement.

Model	MH-106A
Power supply	3P 380V 50/60HZ 750W 5A
Packing speed	<=7second/cycle
Table height	450~750mm(Custom-made height available)
Frame size	Width 800mm, height depending on actual conditions.
Hot-adhering position	Side face
Packing type	Parallel 1-several strips, in type of order to pack, pedal switch and continually manual packing and continual packing.
Applicable straps	Thickness(0.55~1.2)mm, width(9~15)mm (can design for actual require)
Electric appliances adopted	LG"PLC" control, French "TE",Japanese "OMRON" and "ZIK".
G.W/N.W	300kg/220kg



Article number	Dimension	Sleeve φ	Roll length	Tensile strength
5047	5x0.47	200x190mm	7000mm	52kg
6055	6x0.55	200x190mm	4700mm	40kg
8045	8x0.45	200x190mm	4500mm	80kg
8045	8x0.45	200x190mm	4500mm	60kg
9050	9x0.50	200x190mm	4000mm	85kg
9055	9x0.55	200x190mm	3500mm	70kg
10055	10x0.55	200x190mm	2700mm	110kg
10065	10x0.65	200x190mm	2400mm	135kg
12055	12x0.55	200x190mm	2500mm	120kg
12063	12x0.63	200x190mm	2000mm	135kg
15090	15x0.90	200x190mm	1400mm	150kg

world advanced packing system

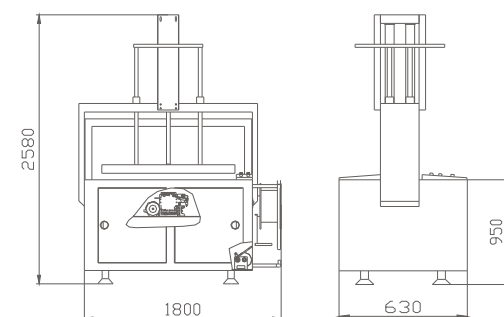

MH-106A)

