

Labeling Machine



A series

A2000 Labeling Machine

Model	A2000
Power supply	220V 50Hz 400W
Applied material	Stick-label
Label size	L(15-300) mm×H(15-130)mm
Package dimension	Dia ϕ 20~ ϕ 80; H(25~300)mm
Label speed	0~75pcs/min (only one label); 0~50pcs/min (two labels)
Optional	Code printer



AB2000 Labeling Machine

Model	AB2000
Power supply	220V 50Hz 500W
Applied material	Adhesive label
Label size	L(15-300) mm×H(15-130)mm
Package dimension	Dia ϕ 20~ ϕ 80; H(25~300)mm
Label speed	0~75pcs/min (only one label); 0~50pcs/min (two labels)
Optional	① Code printer ② bottle trimer ϕ 800mm

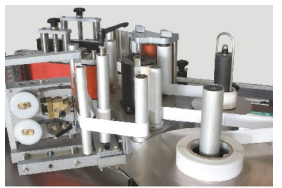

world advanced packing system

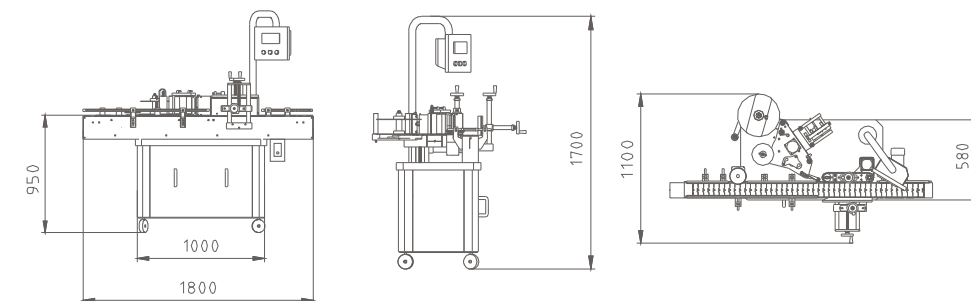
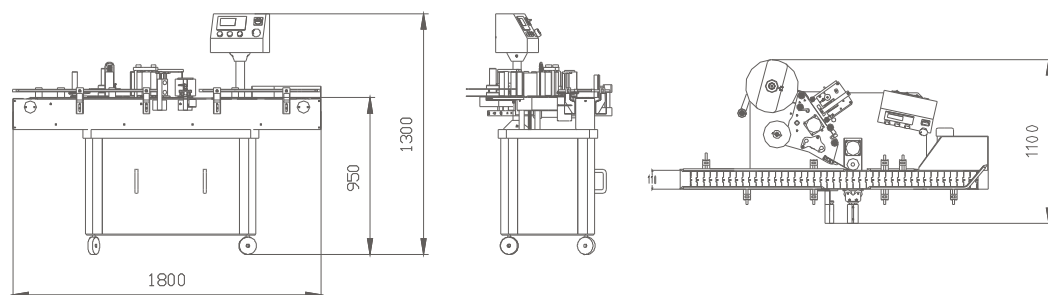

AC2000 Automatic Labeling Machine

Model	AC2000
Power supply	220V 50Hz 500W
Applied material	Stick-label
Lable size	L(15-300) mm×H(15-130)mm
Package dimension	Dia φ 20~ φ 80 H(25~300)mm
Diameter of package	φ 10~ φ 50mm
Label speed	full label and no-coding 0~250/min full label and coding 0~220/min no-full label and no-coding 0~280/min no-full label and coding 0~250/min
Optional	①Code printer ②bottle trimer φ 800mm



B2000 Automatic Labeling Machine

- Can pack the front and back of the thing to glue two labels at the same time in flat surface or ovals

Model	B2000
Power supply	1P 220V 50/60Hz 600W
Applied material	Undried glue lable
Lable size	L(15-300) mm×H(50-130)mm
Package dimension	Dia φ 25~ φ 120; H(40~300)mm
Label speed	0~120pcs/min
Optional	Code printer

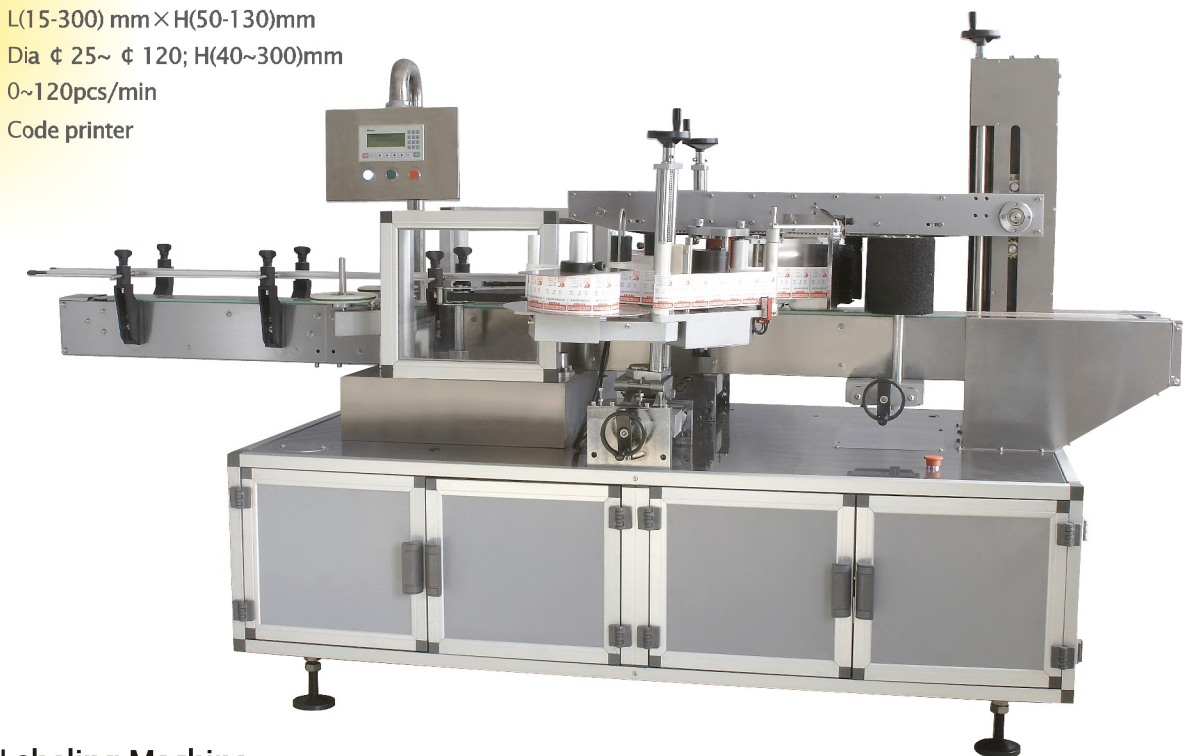

B76 Semi-automatic Labeling Machine

Model	B76
Power supply	1P 220V 50/60Hz 600W
Applied material	Undried glue lable
Lable size	L(15-350) mm×H(15-130)mm
Package dimension	Dia φ 45~ φ 110 H (40~350)mm
Label speed	0~50pcs/min

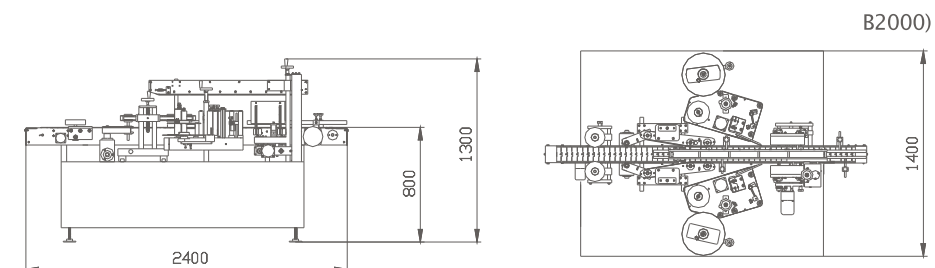
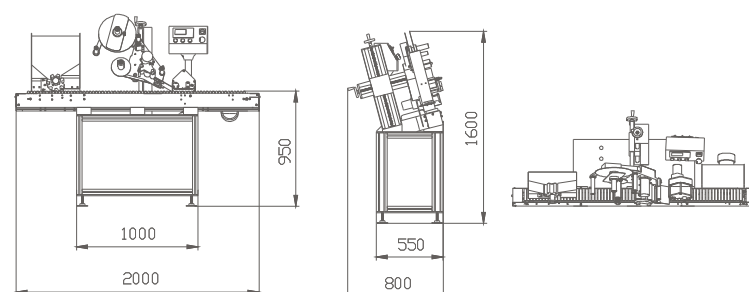
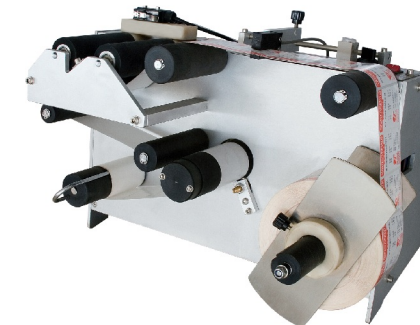

C series

D series

CA2000 Automatic Labeling Machine

Model	CA2000
Power supply	220V 50Hz 100W
Applied material	Undried glue lable
Lable size	L(15-300) mm×H(15-130)mm
Wrappage dimension	H(20~300)mm W(10~200)mm
Label speed	0~90pcs/min
Optional	①Code printer ②bottle trimer φ 800mm



CB2000 Automatic Labeling Machine

Model	CB2000
Power supply	1P 220V 50/60Hz 200W
Applied material	Undried glue lable
Lable size	L(15-300) mm×H(10-150)mm
Package dimension	L(20~300)mm W(10~200)mm
Label speed	0~300pcs/min



D-1 Labeling Machine

- Heated code printer, can be used for all kinds of labeling machine, capable of printing DLC, the DLV bar codes and product batches.

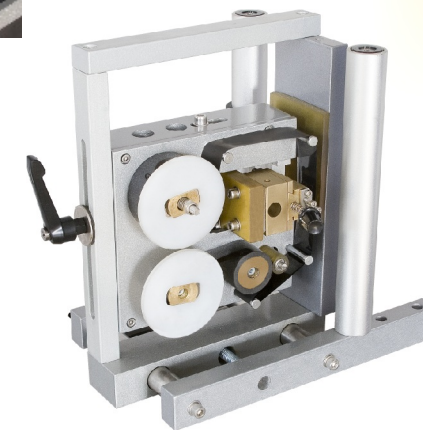

world advanced packing system

